



Solenoid valve 2/2 way N.C. Direct acting

21A1KV15
÷
21A1KV30

PRESENTATION:

Direct acting S.V. for interception of fluids compatible with the construction materials.

Minimum operational pressure is not required.

The materials used and the tests carried out ensure maximum reliability and duration.

USE: Automation
Heating

PIPES: subplate mounting

COILS 8W - Ø 13 (1)
BDA - BDS - BSA 155°C (class F)
BDF - BDV 180°C (class H)
12W - Ø 13
UDA 155°C (class F)
14W - Ø 13
GDH - GDV 180°C (class H)
(1) Explosion-proof housing for coils with electrical connections EN 175301-803 on request.

MOULDING AND BOBBIN ARE MADE BY 100% VIRGIN MATERIAL.

Max. allowable pressure (PS) 40 bar
Ambient temperature:
with coils class F -10°C + 60°C
with coils class H -10°C + 80°C



Gaskets	Temperature		Medium
	- 10°C	+140°C	
V=FKM (fluoroelastomer)	- 10°C	+140°C	Mineral oils (2°E), gasoline gas oil, fuel oils (7°E)
B=NBR (nitrile rubber)	- 10°C	+ 90°C	Air, inert gas, water
E=EPDM (ethylene-propylene)	- 10°C	+140°C	Water, steam

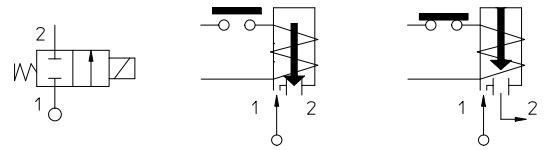

For seals other than FKM replace the letter "V" with the ones corresponding to the other seals. E.I. 21A1KB15.

Pipe	Code	Max viscosity		Ø mm	Kv l/mn	Power (watt)	Pressure		
		cSt	°E				min bar	M.O.P.D.	
								AC bar	DC bar
SUBPLATE MOUNTING	21A1KV15	12	~ 2	1,5	1,4	0	30	18	
	21A1KV20	37	~ 5	2	2		22	16	
							35	30	
	21A1KV25	53	~ 7	2,5	3,2		8	14	9
							12	30	25
							14	10	6
	21A1KV30	53	~ 7	3	4	8	25	18	
						12		20	
						14			

The "ODE" reserves the right to carry out technical and aesthetic modifications without prior notification.

MATERIALS:

Body	Brass - UNI EN 12165 CW617N
Armature tube	Stainless steel AISI series 300
Fixed core	Stainless steel AISI series 400
Plunger	Stainless steel AISI series 400
Phase displacement ring	Copper - Cu 99,9%
Spring	Stainless steel AISI series 300
Seal	Standard: V=FKM On request: B=NBR E=EPDM
Orifice: Insert slot	Stainless steel AISI series 300

On request:

Connector	Pg 9 or Pg 11
Connector conformity	ISO 4400

FEATURES:

Electrical conformity	IEC 335
Protection degree	IP 65 EN 60529 (DIN 40050) with coil fitted by connector.

SPARE PARTS:

- Coil:**
See coils list
- Complete plunger:**
Code R450886/V
- Complete armature tube:**
Code R450606
- Gasket O-Ring:**
Code R990002/V

KIT:

KT130KV30-A=2+3

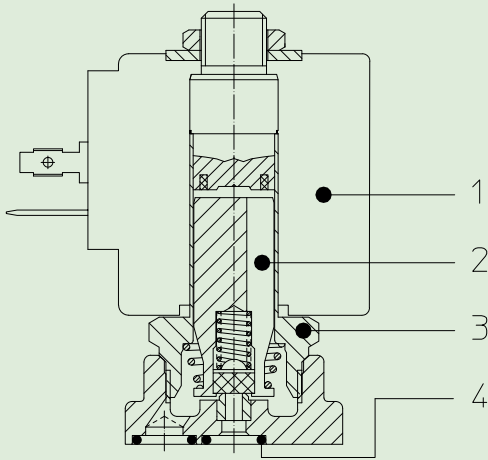

DIMENSIONS:

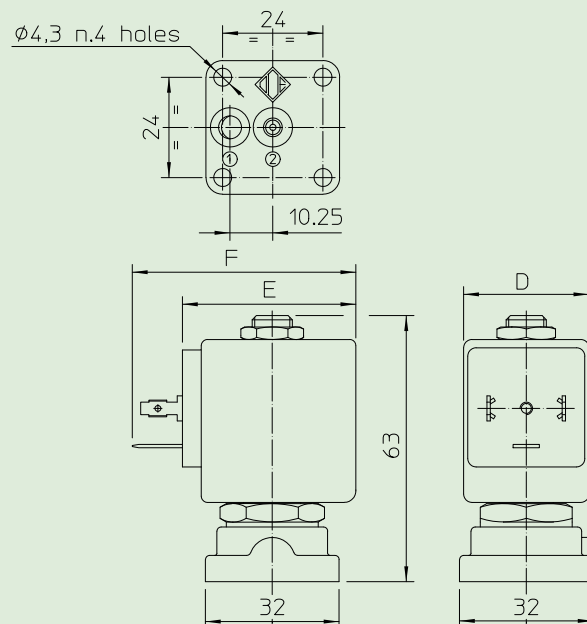

COIL TYPE	POWER ABSORPTION			DIMENSIONS		
	W ==	Hold VA ~	Inrush VA ~	D mm	E mm	F mm
B	8	14,5	25	30	42	54
U	12	23	35	36	48	60
G	14	27	43	52	55	67