



Solenoid valve 2/2 way N.C. With pilot control

21W3KV190
÷
21W7KE500

PRESENTATION:

S.V. with pilot control for interception of fluids compatible with the construction materials.

A minimum operational pressure of 0,2 bar is required.

The materials used and the tests carried out ensure maximum reliability and duration.

USE: Automation
Heating

PIPES: G 3/4 - G 2

COILS: 8W - Ø 13
BDA -BDS - BSA 155°C (class F)
BDP 160°C (high temperature)
BDF 180°C (class H)
SDH 180°C (class H)



Max. allowable pressure (PS)

G 3/4 - G 1 25 bar
G 1 1/4 - G 2 16 bar

Environment temperature:

with class **F** or high temperature coils - 10°C + 60°C
with class **H** coil - 10°C + 80°C

Gaskets	Temperature		Medium
B =NBR (nitrile rubber)	- 10°C	+ 90°C	Air, inert gas, water
E =EPDM (ethylene-propylene)	- 10°C	+140°C	Water, low pressure steam
V =FKM (fluoroelastomer)	- 10°C	+140°C	mineral oils (2°E), gasoline gas oil

For seals other than NBR replace the letter "B" with the ones corresponding to the other seals. E.I. 21W3KE120.

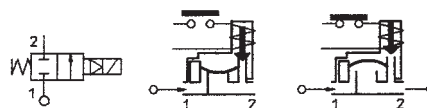

Pipe ISO 228/1	Code	Max viscosity		Ø mm	Kv (l/mn)	Power (watt)	Pressure		
		cSt	°E				min bar	M.O.P.D. AC bar DC bar	
G 3/4	21W3KV190	12	~ 2	19	140	8	0,2	16	16
G 1	21W4KV250			25	190				
G 1 1/4	21W5KV350			35	400				
G 1 1/2	21W6KV400			40	520				
G 2	21W7KE500			50	750				



CE Approval
(Pressure Equipment Directive 97/23/CE)

for S.V. 21W5÷21W7

The "ODE" reserves the right to carry out technical and aesthetic modifications without prior notification.

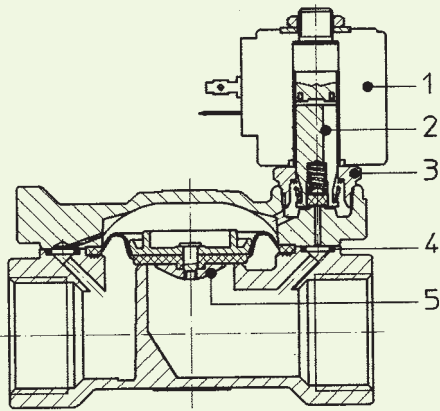

MATERIALS:

Body Brass - UNI EN 12165 CW617N
Armature tube Stainless steel AISI series 300
Fixed core Stainless steel AISI series 400
Plunger Stainless steel AISI series 400
Phase displacement ring Copper - Cu 99,9%
Spring Stainless steel AISI series 300
Seal Standard: B=NBR
 On request: E=EPDM V=FKM
Orifice Brass - UNI EN 12165 CW617N

On request: Pg 9 or Pg 11
Connector ISO 4400
Connector conformity

FEATURES:

Electrical conformity IEC 335
Protection degree IP 65 EN 60529 (DIN 40050)
 with coil fitted by connector.

SPARE PARTS:

- 1. Coil:** See coils list
- 2. Complete plunger:** Code R450886/B
- 3. Complete armature tube:** Code R450606
- 4. Gasket O-Ring:**
 - G 3/4-G 1 Code R990002/B
 - G 1 1/4-G 1 1/2 Code R990005/B
 - G 2 Code R990081/B
- 5. Complete diaphragm:**
 - G 3/4-G 1 Code R450431/B
 - G 1 1/4-G 1 1/2 Code R450466/B
 - G 2 Code R450432/B

KIT:

KT130KB30-A=2+3

MAINTENANCE KIT:

G 3/4-G 1
 KTG0W3KB19=2+4+5
 G 1 1/4-G 1 1/2
 KTG0W5KB35=2+4+5
 G 2
 KTG0W7KB50=2+4+5

DIMENSIONS:

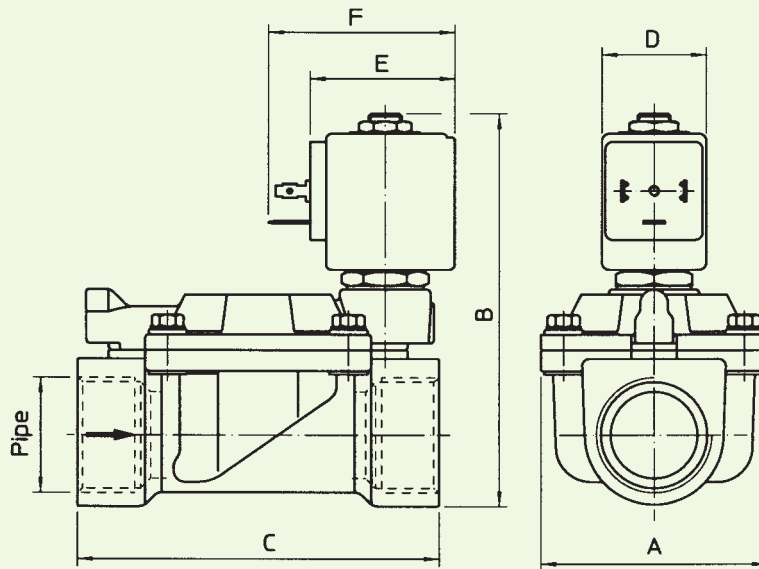

Type	Pipe ISO 228/1	A mm	B mm	C mm
21W3KB190	G 3/4	65	105	104
21W4KB250	G 1		112	
21W5KV350	G 1 1/4	98	125	144
21W6KB400	G 1 1/2			
21W7KB500	G 2	118	141	172

COIL	POWER ABSORPTION		TYPE	DIMENSIONS		
	Inrush VA ~	Hold VA ~		D mm	E mm	F mm
8 W	25	14,5	B	30	42	54
			S	32		