



Solenoid valve 2/2 way N.C. modular With pilot control

4743K0V120

PRESENTATION:

S.V. with pilot control for interception of fluids compatible with the construction materials.

A minimum operational pressure of 0,1 bar is required.

The materials used and the tests carried out ensure maximum reliability and duration.

USE: Car wash

PIPES: Inlet flange - G 1/2 outlet

COILS:
 8W - Ø 13
 BDA -BDS - BSA 155°C (class F)
 BDF - BDV 180°C (class H)
 12W -Ø 13
 UDA 155°C (class F)

MOULDING AND BOBBIN ARE MADE BY 100% VIRGIN MATERIAL.

Max. allowable pressure (PS) 20 bar
 Ambient temperature:
 with coil class **F** - 10°C + 60°C
 with coil class **H** - 10°C + 80°C



Gaskets	Temperature		Medium
V=FKM (fluoroelastomer)	- 10°C	+140°C	Water

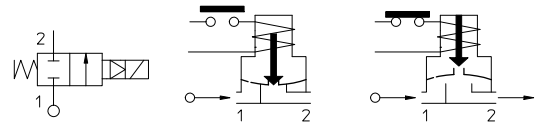

Pipe	Code	Max viscosity		Ø mm	Kv l/mn	Power (watt)	Pressure		
		cSt	°E				min bar	M.O.P.D. AC bar DC bar	
FLANGE	4743K0V120	12	~ 2	12	40	8	0,1	16	10
						12		-	16

Note

Available on request and with minimum quantities.

The "ODE" reserves the right to carry out technical and aesthetic modifications without prior notification.

MATERIALS:

Body	Brass - UNI EN 12165 CW617N
Welded armature tube	Stainless steel AISI series 300
Fixed core	Stainless steel AISI series 400
Plunger	Stainless steel AISI series 400
Phase displacement ring	Copper - Cu 99,9%
Spring	Stainless steel AISI series 300
Seal	V=FKM
Orifice	Brass - UNI EN 12165 CW617N

On request:

Connector	Pg 9 or Pg 11
Connector conformity	ISO 4400

FEATURES:

Electrical conformity	IEC 335
Protection degree	IP 65 EN 60529 (DIN 40050) with coil fitted by connector.

SPARE PARTS:

- | | |
|--|--|
| 1. Coil:
See coils list | 6. Screw M5x16:
Code R990455 |
| 2. Complete plunger:
Code R451284/V | 7. Nut M5x4:
Code R990468 |
| 3. Complete cover with armature tube:
Code R450938 | |
| 4. Complete diaphragm:
Code R450916/V | |
| 5. Gasket O-Ring:
Code 990146/V | |

MAINTENANCE KIT:

KTG0H7KV12=2+4

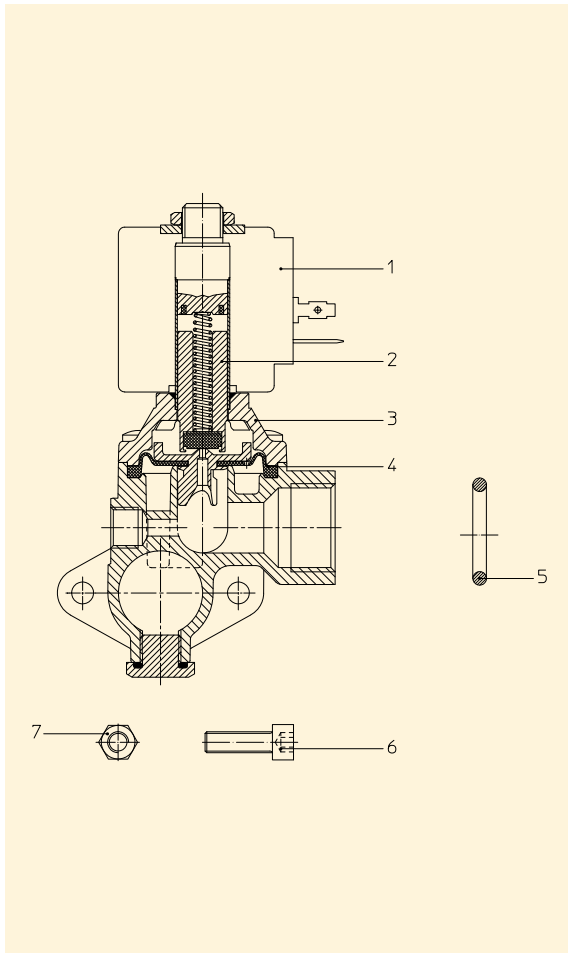

DIMENSIONS:

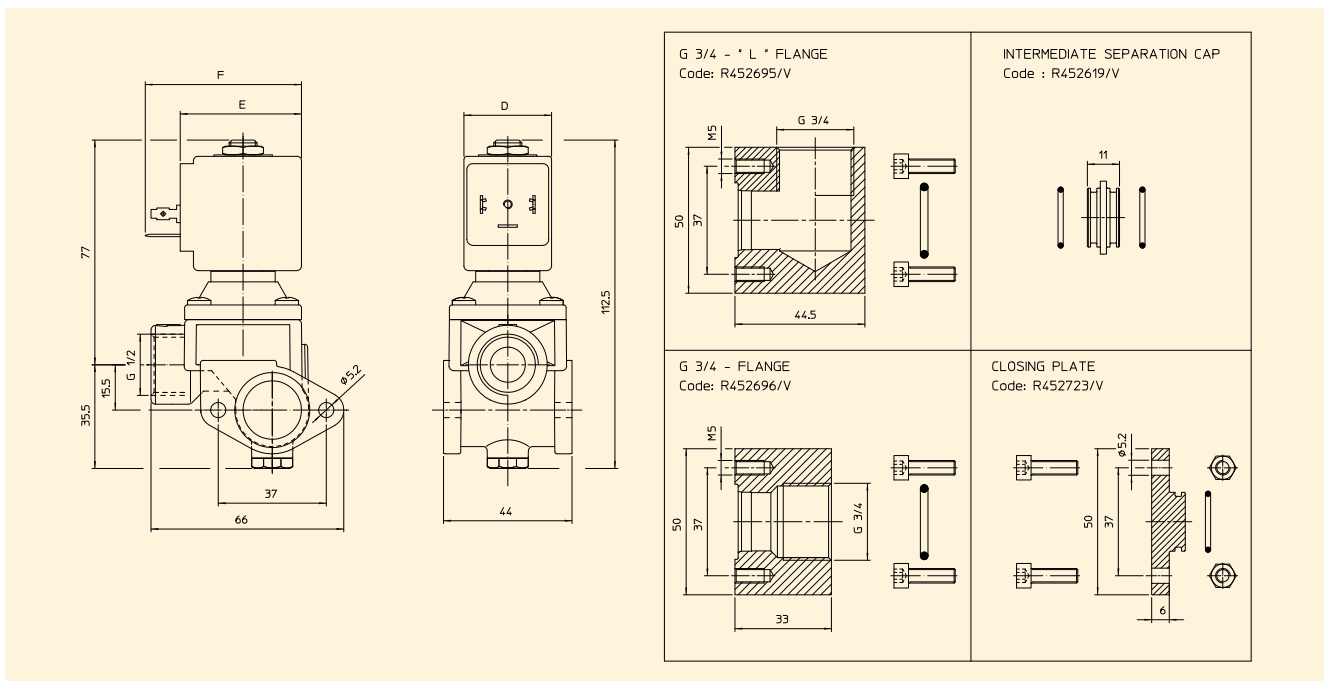

COIL TYPE	POWER ABSORPTION			DIMENSIONS		
	W =	Hold VA ~	Inrush VA ~	D mm	E mm	F mm
B	8	14,5	25	30	42	54
U	12	23	35	36	48	60