



**Total separation solenoid valve
2/2 way N.C. with flow regulation
Direct acting - NSF Certified**

21K72KRS90-000

÷

26K72KRS90-000

PRESENTATION:

Bank S.V. for automatic drink dispensers.
Minimum operational pressure is not required.
The materials used and the tests carried out ensure maximum reliability and duration.

USE: Automatic drink dispensers

PIPES: Please turn over (A-B-D-I-L-R)

BOBINE: 8W - Ø 13
BDA - BDS - BSA 155°C (class F)
BDP 160°C (high temperature)
BDF 180°C (class H)

Environment temperature:
with class **F** or high temperature coils - 10°C + 60°C
with class **H** coil - 10°C + 80°C



Gaskets	Temperature		Medium
S=VMQ (silicone)	+ 2°C	+100°C	Water

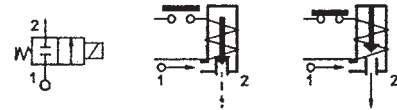

Pipe	Code	Max viscosity		Ø mm	Kv l/mn	Power (watt)	Pressure		
		cSt	°E				min bar	M.O.P.D. AC bar DC bar	
See connection types overleaf (A-B-D-I-L-R)	21K72KRS90-000	-	-	9	*	8	0	0,3	0,3
	22K72KRS90-000								
	23K72KRS90-000								
	24K72KRS90-000								
	25K72KRS90-000								
	26K72KRS90-000								

* FLOW RATE WITH HEAD OF 80 mm = 2,5 l/min.

NSF CERTIFIED



The "ODE" reserves the right to carry out technical and aesthetic modifications without prior notification

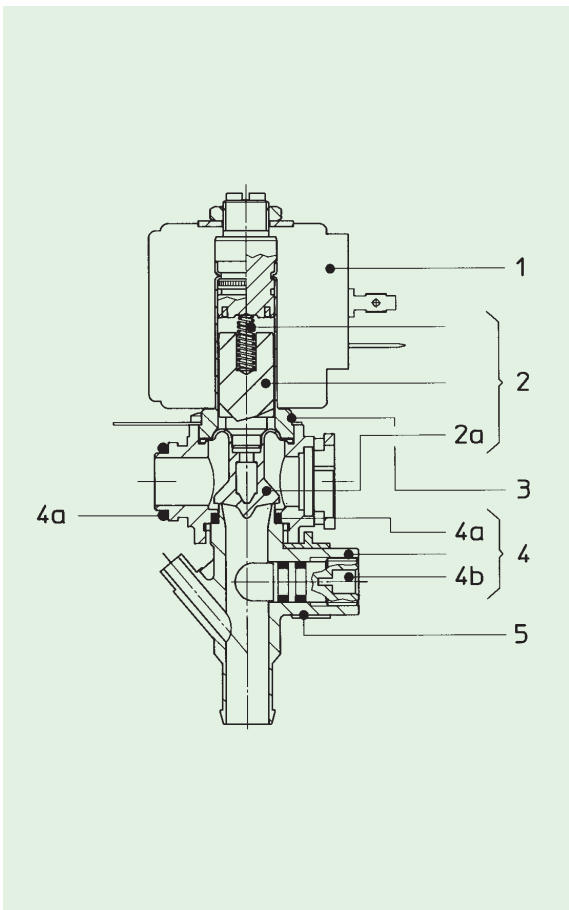

MATERIALS:

- Body** PSU (Polysulphone)
- Lower body** PSU (Polysulphone)
- Lower body clamping device** PA (Polyamide)
- Armature tube** Brass - UNI EN 12164 CW614N
- Fixed core** Stainless steel AISI series 400
- Plunger** Stainless steel AISI series 400
- Phase displacement ring** Copper - Cu 99,9%
- Spring** Stainless steel AISI series 300
- Bellow membrane** Standard: S = VMQ
On request W = MFQ

SPARE PARTS:

- 1. Coil:**
See coils list
 - 2. Complete plunger:**
Cod. R452491/S
 - 2a. Bellow membrane:**
Code R452489/S
 - 3. Complete armature tube:**
Code R452197
 - 4. Lower body assembly:**
Code R452493
 - 4a. Gasket O-Ring:**
Code R990052/S
 - 4b. Flow setting screw with O-Ring:**
Code R452226
 - 5. Lower body clamping device:**
Code R452259
- KIT:**
KR130KRS90-L3=2+3

DIMENSIONS:

SOLENOID VALVE CODING WITH ACCESSORIES

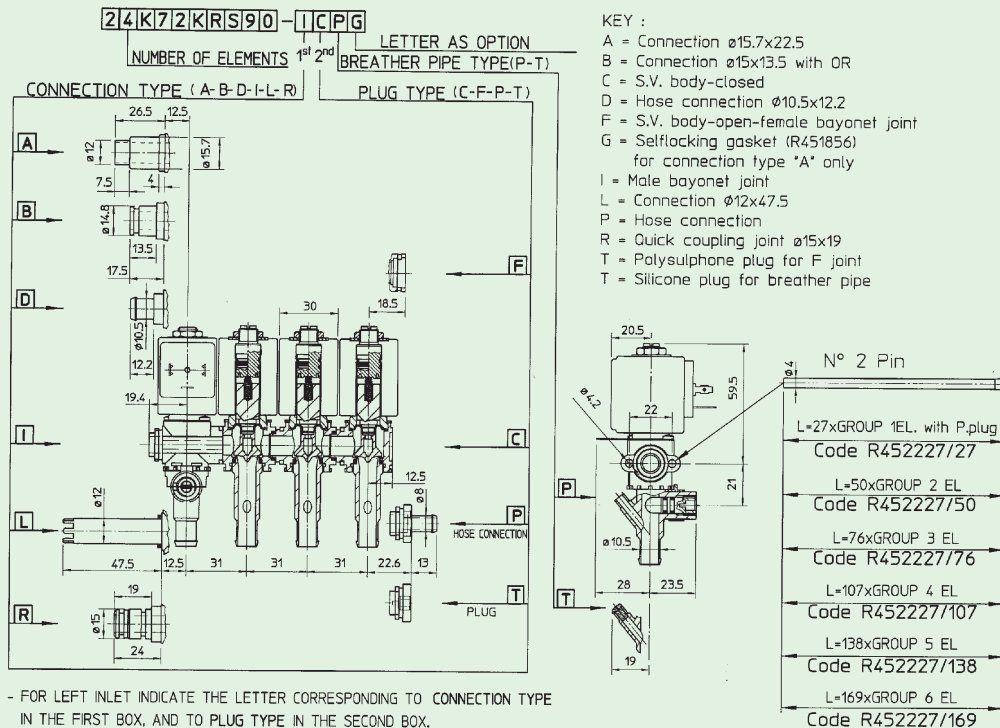

COIL	POWER ABSORPTION		TYPE
	Inrush VA ~	Hold VA ~	
8 W	25	14,5	B